

# Multi Output Functional Repeater



The MOFR is a compact DIN rail mountable high isolation signal repeater and IRIG converter that provides galvanic isolation between synchronized devices or bays of equipment and can also simplify wiring.

## MODEL: MOFR01-5LD

The primary copper and fiber inputs in the MOFR01-5LD accept DCLS IRIG-B or digital pulses. When a DCLS IRIG-B signal or digital pulse is received on one of the primary inputs, the MOFR isolates, regenerates and amplifies the signal on the primary fiber, TTL, RS232 and RS422/ 485 outputs simultaneously.

If a DCLS IRIG-B signal is received on the copper or fiber input, the MOFR will isolate, and regenerate the signal as AM IRIG-B.

		INPUT			
		DCLS TTL	DCLS RS232	DCLS RS422	ST Fiber
OUTPUT	DCLS TTL	✓	✓	✓	✓
	DCLS RS232	✓	✓	✓	✓
	DCLS RS422	✓	✓	✓	✓
	ST Fiber	✓	✓	✓	✓
	AM IRIG-B	✓	✓	✓	✓

## Functional Diagram

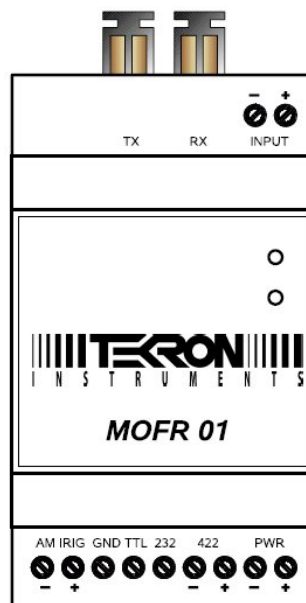
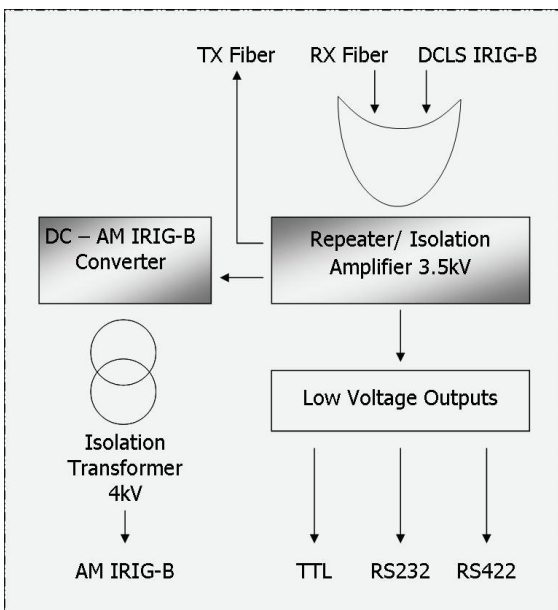

## About Tekron

Tekron International is a leading developer of exceedingly accurate GPS clocks and time synchronization solutions for use in industrial applications.

Tekron GPS clocks are simple to install and use and are extremely rugged; attributes that are a prerequisite in the often extreme environments in which the clocks are installed.

Tekron GPS clocks have been installed in thousands of power stations & substations across the globe, where they prove invaluable in assisting power companies to operate efficiently, minimizing downtime and increasing the accuracy of control decisions.

With a Tekron GPS clock you can be confident that you can set it up and walk away.